

DESCH DRIVE- AND SYSTEM SOLUTIONS

for machine tools



DESCH DRIVE- AND SYSTEM SOLUTIONS FOR MACHINE TOOLS

As one of the market leaders in the development and production of complex, customized drive systems, DESCH provides planetary gearboxes and special gearboxes for cutting and splitting machine tools.

In this field, DESCH combines decades of know-how with use of ultra-modern machinery to offer premium-quality products.

DESCH gearboxes offer the perfect solution for each client due to selectable ratios and selectable internal bore diameters. DESCH responds to the demand for increased rotation speeds and increased torques by offering customized gearing, bearing and lubrication systems.

Besides our proven planetary gearboxes DESCH offers an almost complete product range for your drive solution such as motor spindle, machining heads, flexible couplings, tooth clutches, v-belts and pulleys, tooth gears, valve blocks for the hydraulic units for lube oil and actuation oil and also measurement systems for condition monitoring which further enhances the idea of industry 4.0. The system collects and forwards data to the NC-processor of the machine.

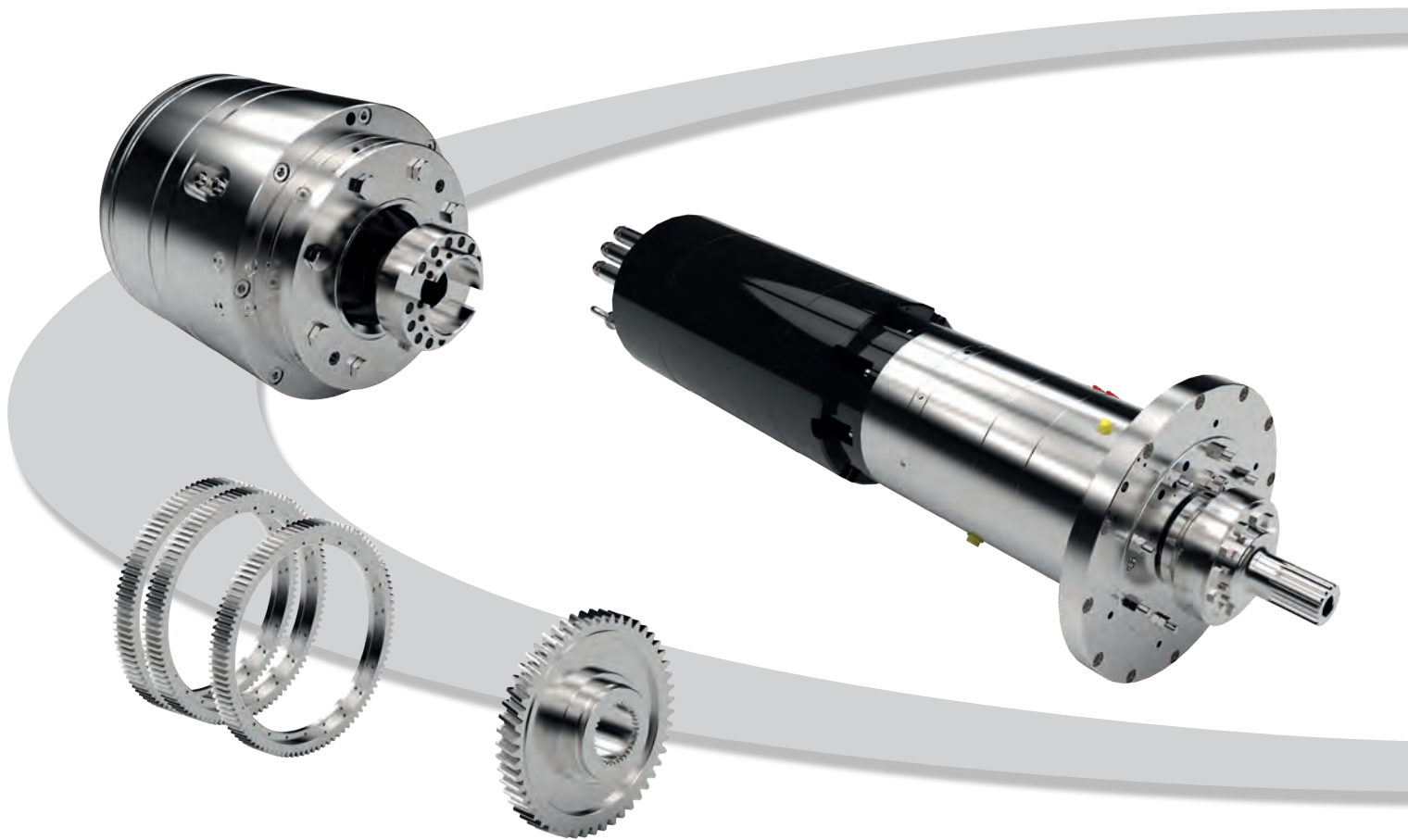

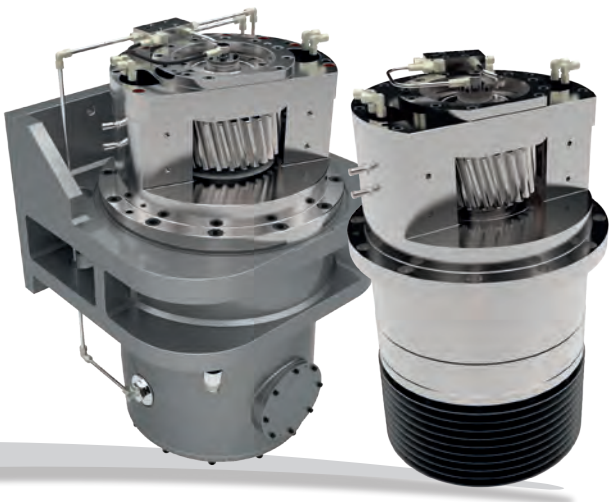

INNOVATIVE,
CUSTOMIZED SOLUTIONS
FOR YOUR
COMPLETE DRIVE LINE



DESCH PLANETARY SHIFTING GEARBOXES

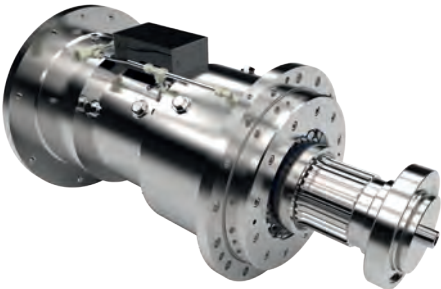
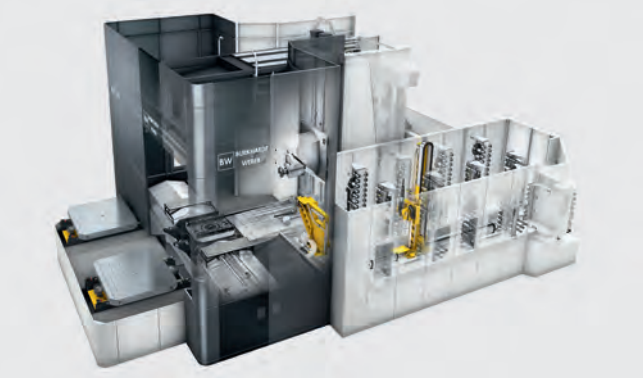

DESCH KNOW-HOW

Experience with latest technology and highly skilled associates guarantee high-tech performance in manufacturing machine tool gearboxes.

The components for DESCH gearboxes are manufactured by our ultra-modern machinery, using state-of-the-art computerized gearing machines, milling machines, grinding machines and machining centres.

Our test rig for machine tool gearboxes, equipped with computer-monitored testing technology, is also located close to the assembly department on vibration-free foundations in air-conditioned rooms. In this way, the production process is optimized and shortened, which is one of the keys to success.

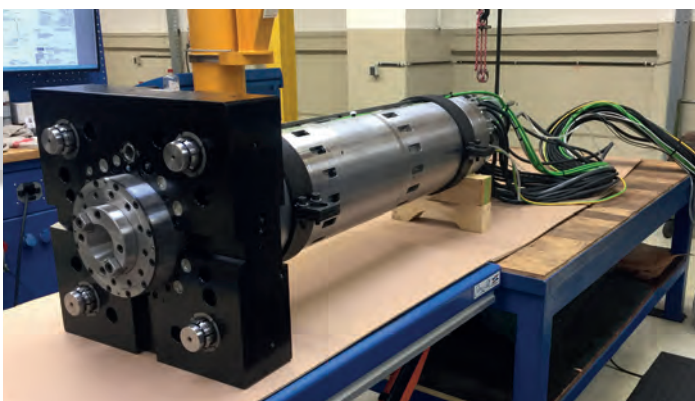
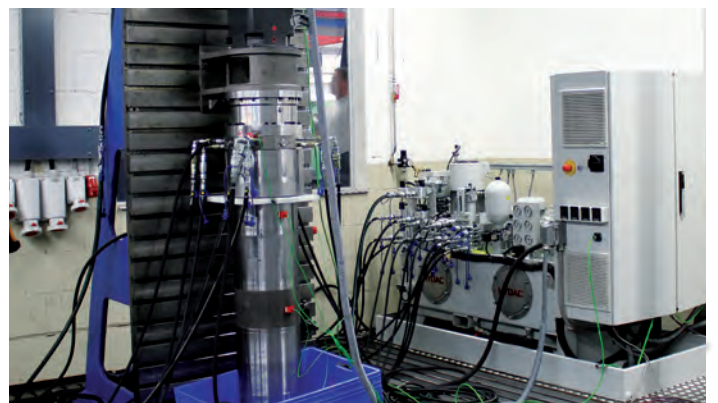

DESCH MOTOR GEARBOX UNIT

Denox® HSE

The drive units of the HSE / HS - series are used with single or multi-stage design as main spindle drives in the power range of 40-125 kW in machine tool applications. They are characterized by their extraordinary compactness. The hydraulic circuits and media ducts for cooling and lubrication are integrated in the transmission housing. As an option a tool release mechanism can be integrated in the motor-gearbox unit (drawbar). Data such as temperature, vibration and position can be reported to the machine control unit.

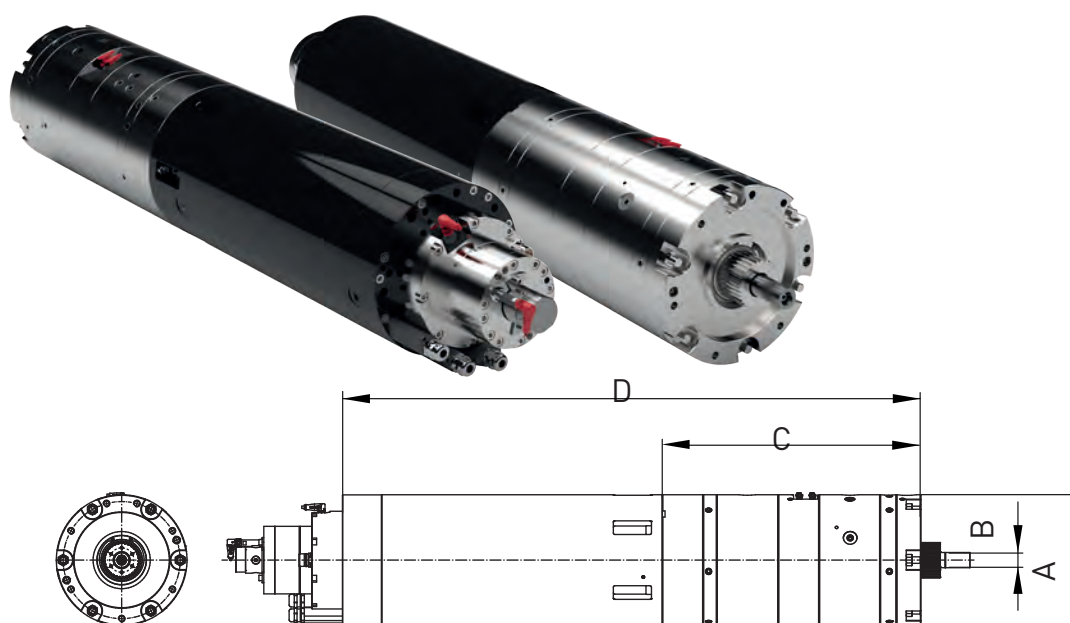

Rated data			HSE40	HSE60	HSE80	HSE100
Power	P	kW	40	60	80	100
Rated speed	n	rpm	1500	1400	1200	955
Rated torque	T1	Nm	250	400	650	1000
Ratio ^[1]	i		1 / 5	1 / 5	1 / 5	1 / 5
Nominal torque [S1-100%]	T2	Nm	1250	2000	3250	5000
Max. output speed	n	rpm	7000	6000	4500	4000
External diameter	A	mm	240	260	300	350
Hollow trough shaft diameter ^[2]	B	mm	25	30	35	36
Length of gearbox	C	mm	430	490	550	600
Total unit length ^[3]	D	mm	1150	1250	1300	1400
Mounting position			horizontal / vertical			
Efficiency	eta	%	0,97			

Other ratio [1] and bore diameter [2] on request.

[3] Excl. motor - several motortypes can be offered.

The above specifications and dimensions may vary by location and position and by the engine used in the application.

DESCH MOTOR GEARBOX UNIT

Denox® HS

This results in an installation geometry without distorting elements for interlocking installation with defined interfaces in the RAM contour. Optionally tool spindles with HSK, ISO and other interface can be offered or fitted. Beside of the listed standard sizes, it is also possible to realise customized drive units up to 200 kW.

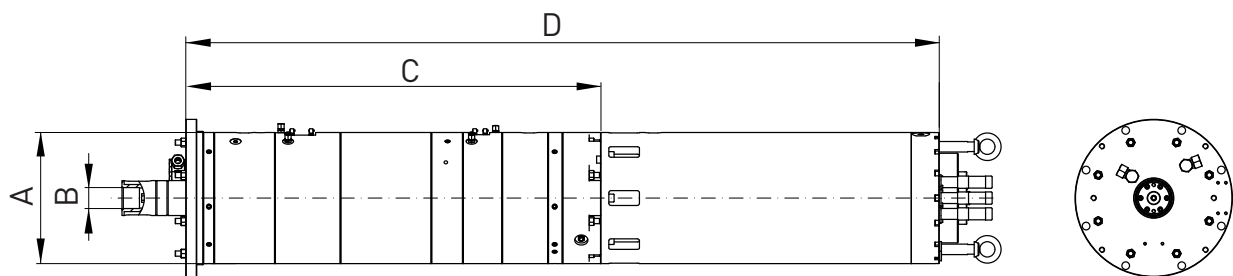

Rated data			HS60	HS80	HS100	HS120	HS140
Power	P	kW	60	80	104	125	140
Rated speed	n	rpm	1460	1200	1700	1500	1300
Rated torque	T1	Nm	390	650	585	800	1000
Ratio ^[1]	i		1,00 / 4,00 / 14,17	1,00 / 3,5 / 12,80	1,00 / 4,50 / 15,88	1,00 / 4,00 / 14,17	1,00 / 4,00 / 16,00
Nominal torque [S1-100%]	T2	Nm	5500	8300	9300	11300	16000
Max. output speed	n	rpm	6000	4500	4500	4500	4000
External diameter	A	mm	260	300	350	350	400
Hollow trough shaft diameter ^[2]	B	mm	35	45	45	45	45
Length of gearbox	C	mm	900	950	970	970	1000
Total unit length ^[3]	D	mm	1750	1800	1700	1700	2000
Mounting position			horizontal / vertical				
Efficiency		%	94				

Other ratio [1] and bore diameter [2] on request.

[3] Excl. motor - several motortypes can be offered.

The above specifications and dimensions may vary by location and position and by the engine used in the application.

DESCH MAIN DRIVES

DESCH main drives for milling-, drilling- and multipurpose machines are characterized by a high power density with low installation size. Especially the combination of a two speed gearbox paired with a spur gearbox as main drive for tool spindles, offers an especially efficient drive- and system solution. The DESCH main drives can be installed horizontal or vertical.

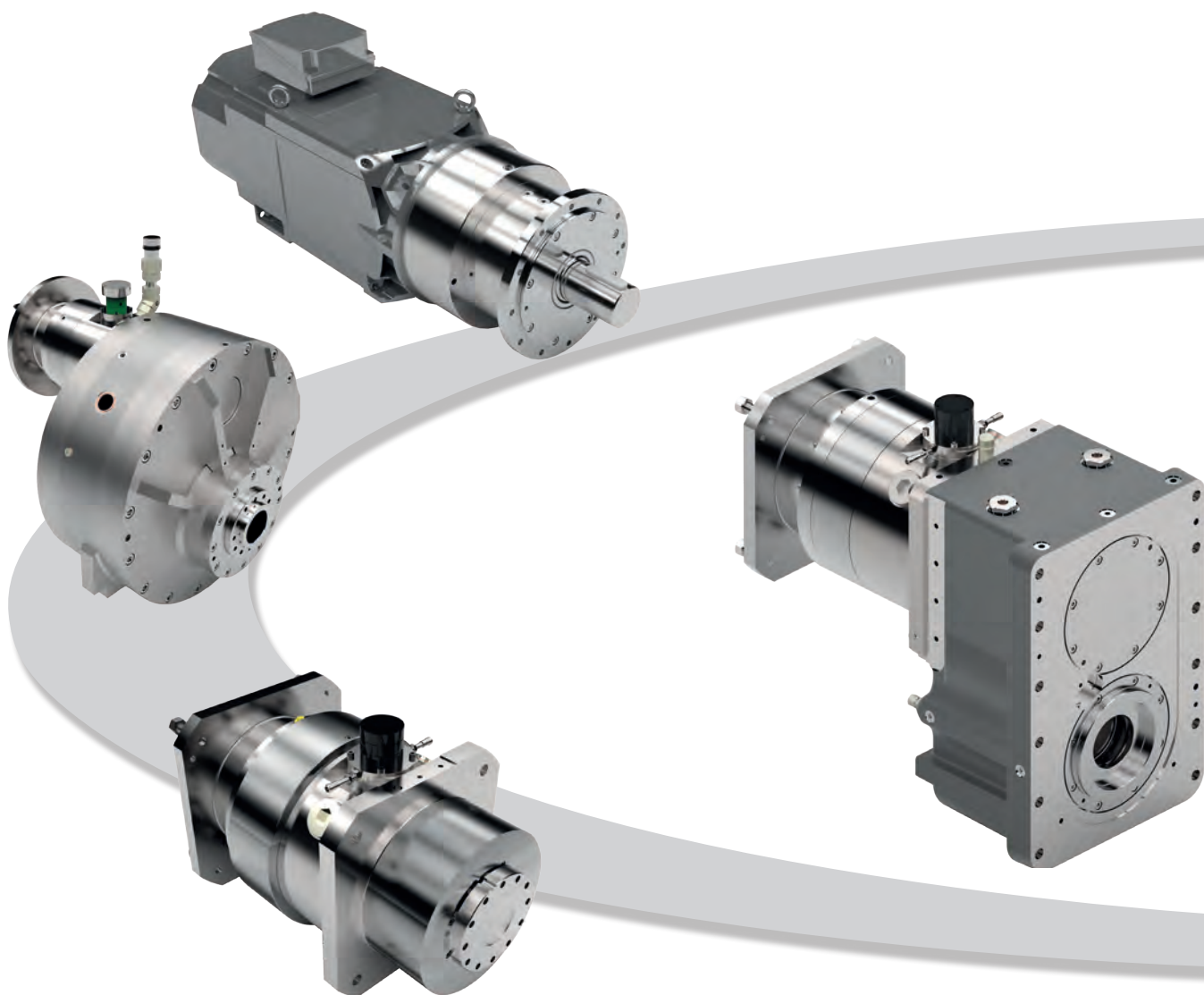

In addition to our main drives for machining main spindles, DESCH also offers a variety of backlash reduced drive systems for cutting, forming, grinding and bending machine tools.



DESCH ROTARY TABLE DRIVE

Denox® DT-ECO

DESCH has expanded its very successful rotary table drive series Denox® DT. The DESCH development team has designed a drive solution that offers higher out-puts at reduced installation space requirements. The new DT-ECO series is available in three sizes and is highlighted by the known DESCH quality and efficiency.

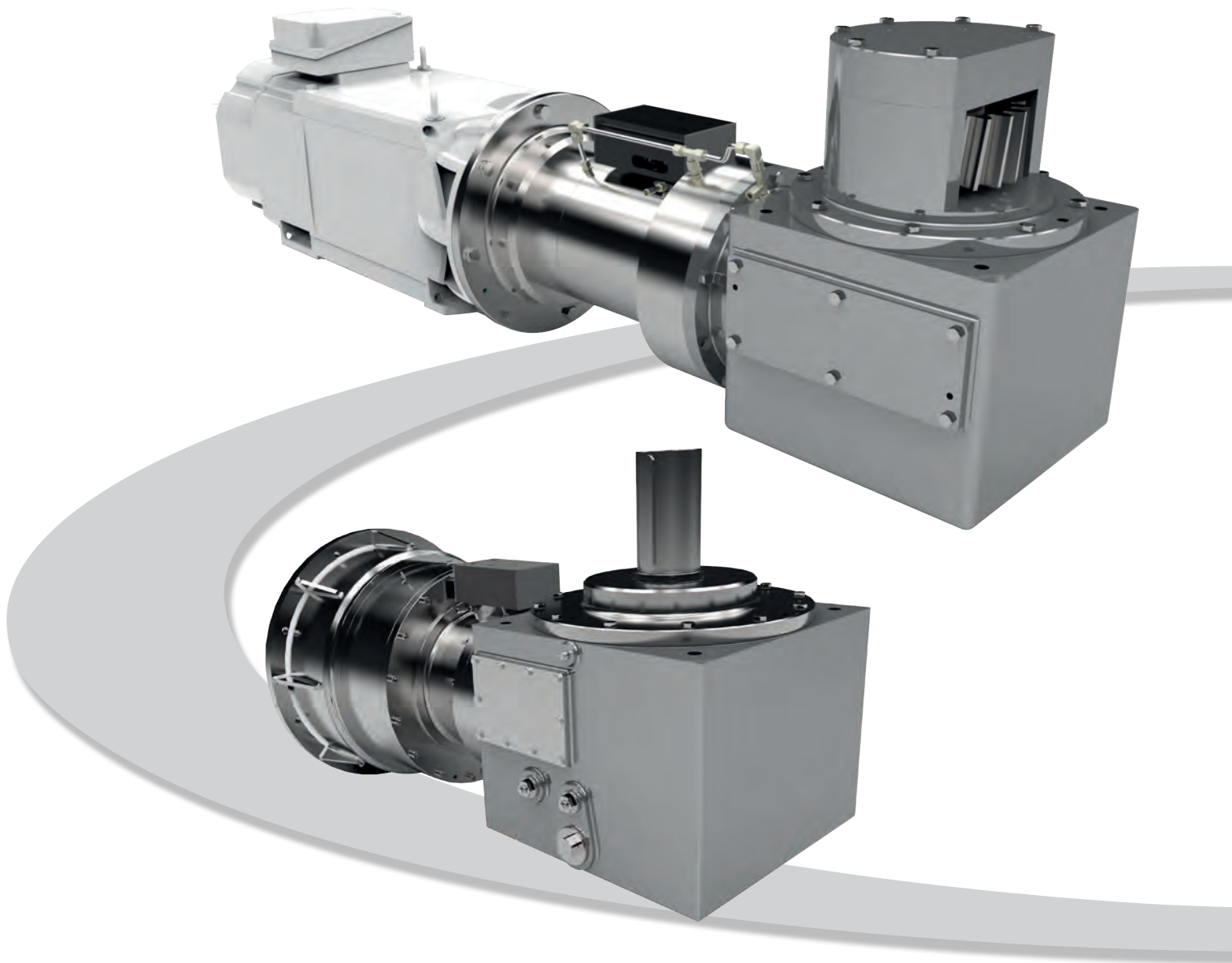

DESCH ROTARY TABLE DRIVE

Denox® DT-ECO

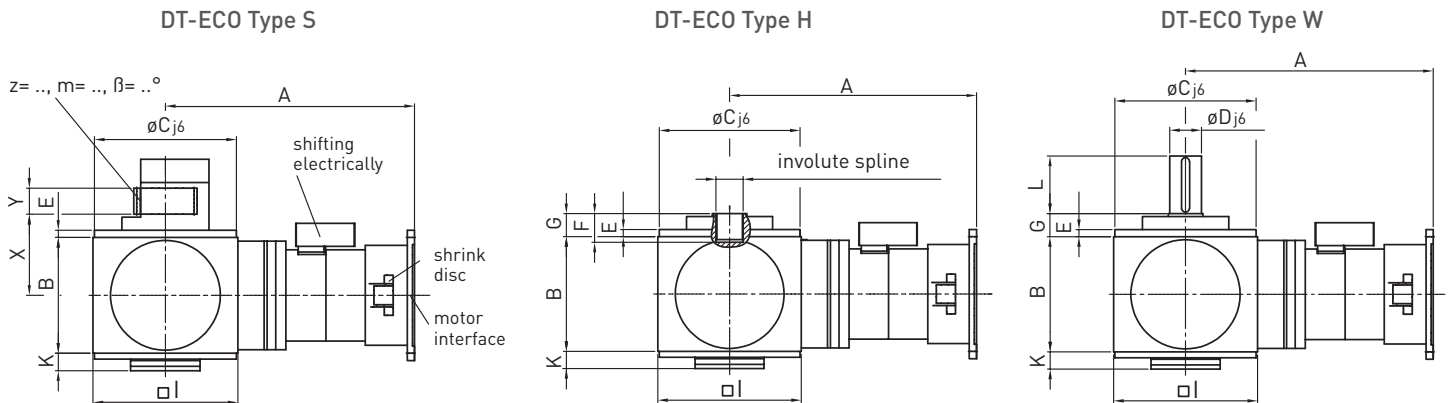

Rated data			DT-ECO 2500	DT-ECO 7000	DT-ECO 9000
Output torque	T	Nm	2500	7000	9000
Max. input speed	n	rpm	6000	5000	4500
High speed ratios	i		2 or 2,2		
Low speed ratios	i		8 or 8,8 ; 10 or 11		
Shifting			electrically actuated with 24V DC-motor incl. two proximity switches for shifting monitoring		
A and motor interface		mm	Depending on motor		
B		mm	315	328	400
C		mm	310	385	490
D		mm	75	90	110
E		mm	15	24	25
F		mm	50	80	80
G		mm	23,5	66	80
Involute spine acc. to DIN 5480		mm	N 60 x 2 x 28	N 80 x 3 x 25	N 95 x 3 x 30
I		mm	315	400	500
K		mm	15	86	60
X, Y, z, m, β°			Depending on customers request		

DESCH ROTARY TABLE DRIVE

Denox® DT

The Denox® DT rotary table drive series can be delivered either with a belt pulley transmission or with a bevel gear, according to the customer's preference. This series covers a performance range from 37 to 130 kW. These shift gearboxes can be used either as single drives to drive faceplates in vertical lathes for continuous turning operation, or by minimizing backlash as dual drives for positioning and milling operations. The drive units feature outstanding compactness and therefore provide highest power density with minimal space requirements. Elastic clutch systems, belt pulleys, cogged belts and gearing components such as intermediate gears and toothed rings from our product range can be added to your drive system as an option to provide a system solution.



DESCH ROTARY TABLE DRIVE

Denox® DT

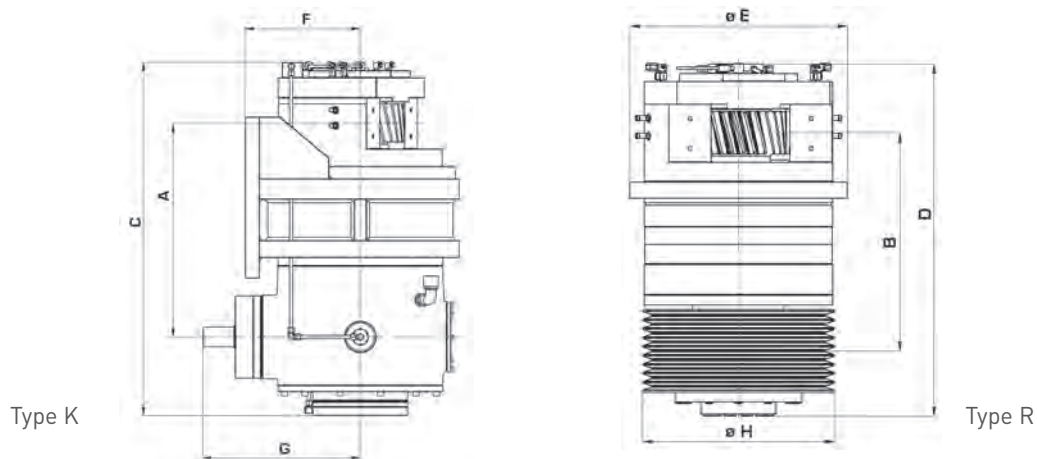

Rated data			DT40K	DT40R	DT50K	DT50R	DT60K	DT60R	DT85K	DT85R	DT130K	DT130R
Power	P	kW	37		46		60		85		130	
Max. input speed	n	rpm	5000	2180 ^[2]	5000	2180 ^[2]	4500	2060 ^[2]	4500	2060 ^[2]	4000	1730 ^[2]
Max. output speed	n	rpm	2273	2180 ^[2]	2273	2180 ^[2]	2045	2060 ^[2]	2045	2060 ^[2]	1818	1730 ^[2]
Ratio ^[1]	i		2,2 / 11	1 / 5	2,2 / 11	1 / 5	2,2 / 9,08	1 / 5	2,2 / 9,08	1 / 5	2,2 / 11	1 / 5
Nominal torque (S1-100%)	T	Nm	2600		3220		4110		5520		12000	
Peak torque (S6-40%)	T	Nm	3460		4300		4930		7360		13600	
A		mm	395		395		490		490		540	
B		mm	380		380		450		450		535	
C		mm	670		670		850		850		910	
D		mm	610		610		750		750		850	
E		mm	435		435		490		490		555	
F		mm	255		255		290		290		320	
G		mm	273		273		380		380		435	
H		mm	350		350		370		370		440	
Switching pressure		bar	40									
Switching position monitoring			inductiv									
Lubrication system			external forced oil lubrication									
Efficiency		%	97									

[1] Adaption of ratio is possible.

[2] Based on V-belt pulley - diameter H.

DESCH MOTOR GEARBOX SPINDLE Denox® MGS AND ACCESSORIES

The DESCH Denox® MGS unit is the perfect combination of all needed components for a powerful drive solution. It consists a watercooled synchronous motor, gearbox with up to 7000 Nm output torque plus machining spindle in various tool interface options such as ISO-BT-HSK-CAPTO. This very compact main spindle design is presently available in 4 sizes up to 110 kW. A special feature is the pre-arranged tool head connection wich can be equipped with a huge variety of DESCH machining heads.

- Motor-gearbox-spindle available in 4 sizes
- Water cooled synchronous motor with output power range 35 to 110 kW
- Shifting gearbox with $i = 1$ and $i = 5$
- Max. output torque 800 to 7.000 Nm
- Max. output speed 3.500 to 10.000 rpm

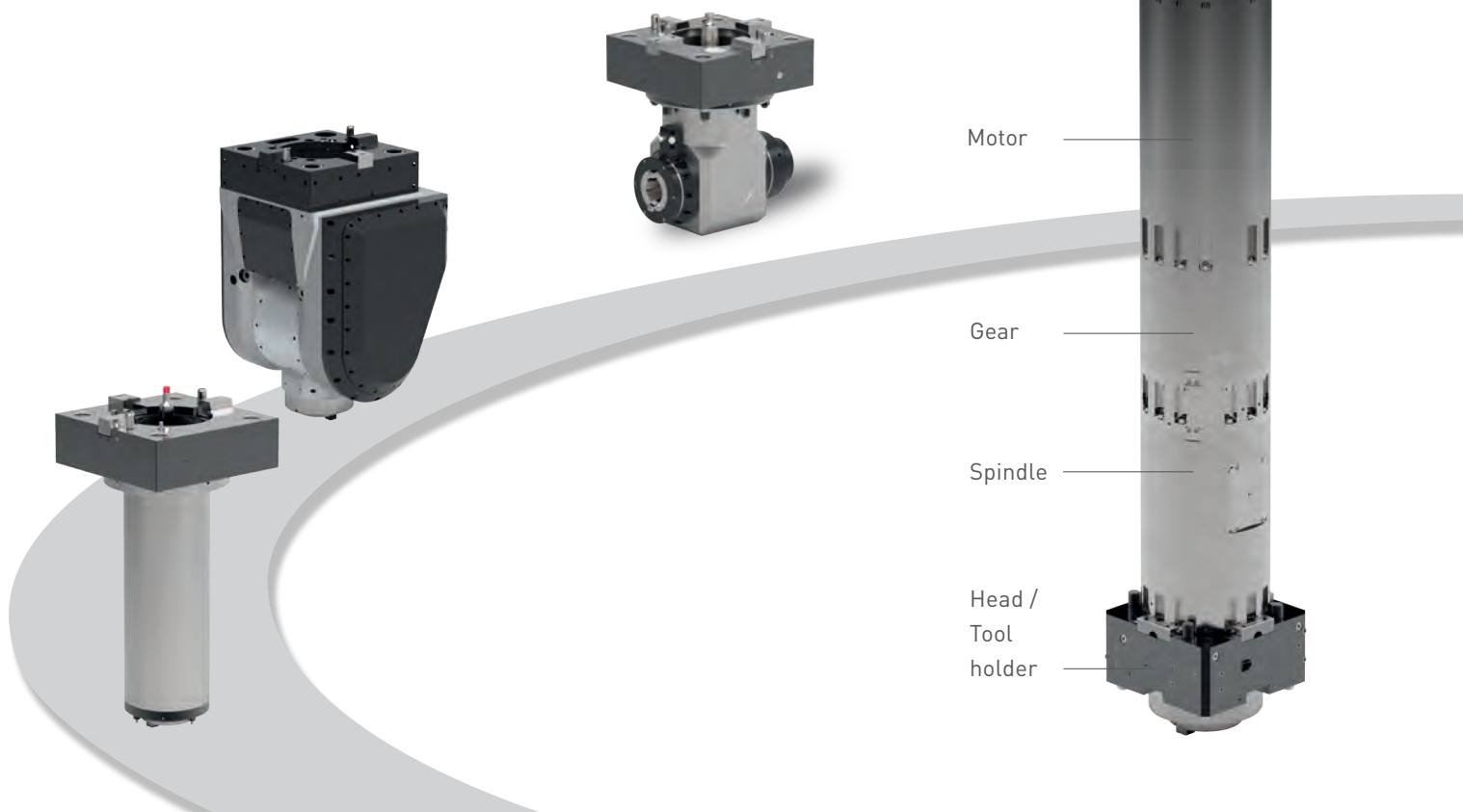

Technical data / size		MGS 1000		MGS 2000		MGS 3000		MGS 7000	
External diameter	mm	250		285		300		400	
Power	kw	40		65		75		110	
Ratio	i	1:1	1:5	1:1	1:5	1:1	1:5	1:1	1:5
Torque	Nm	250	1250	400	2000	600	3000	1400	7000
Nominal speed	rpm	1500	300	1600	320	1200	240	750	150
Max. output speed	rpm	8000	1600	6000	1200	4500	900	3500	700
Tools holder interface	Type	ISO - BT - HSK CAPTO		ISO - BT - HSK CAPTO		ISO - BT - HSK CAPTO		ISO - BT - HSK CAPTO	
Total length	mm	1950		2000		2050		2100	

DESCH MOTOR SPINDLES

The DESCH motor spindle program offers customized drive solutions for milling-, grinding- and turning operations. DESCH offers compact and powerful motor spindles for the installation space of existing machines as well as for newly development drive concepts. The DESCH motor spindles use synchronous or asynchronous build-in motors and offer encoder system based on customer requirements. The tool head connection and the tool clamping system will also be chosen according to customers request.



CONTACT

DESCH Antriebstechnik GmbH & Co. KG
 Postbox 1440
 59753 Arnsberg/Germany
 Kleinbahnstraße 21
 59759 Arnsberg/Germany
 T +49 2932 300 294
 F +49 2932 300 44 294
 machinetooldrives@desch.com
www.desch.com



DESCH Canada Ltd.
 240 Shearson Crescent
 Cambridge
 Ontario
 Canada N 1T 1J6
 T +1800 2631866
 +1519 6214560
 F +1519 6231169
 desch.canada@desch.com

DESCH USA Inc.
 3501 Embassy
 Parkway
 Suite 101
 Akron
 Ohio 44333
 T +1 330 937 9030
 F +1 330 937 9031
 sales_usa@desch.com

DESCH Service Center
 USA LP
 4940 Merrifield Rd
 Dallas
 Texas 75236
 T +1 469 221 2190
 F +1 469 221 2191
 desch.dallas@desch.com

DESCH Italy
 Drive Technology
 Ufficio di rappresentanza
 in Italia
 Via Cavriana, 3
 20134 Milano/Italy
 T +39 02 7391 280
 F +39 02 7391 410
 desch.italia@desch.com

DESCH China
 Machinery (Pinghu) Co., Ltd.
 No. 1680 Xingping 1 Road, Build. 3
 Pinghu Economic Technological
 Development Zone
 314200 Zhejiang P. R. China
 T +86 573 8557 8988
 F +86 573 8557 8989
 desch.china@desch.com

DESCH do Brasil
 Power Transmission S.A.
 Rdv Edgar Máximo
 Zambotto, s/n km 54
 Campo Limpo Paulista, SP
 CEP: 13.231-700
 T +55 11 4039 8240
 F +55 11 4039 8222
 desch.brasilien@desch.com